



Advanced Agricultural Electronics Networks Development

Lecture No. 4, Memory systems and Pointers in C

BAE 5030-352

Spring 2010

Dr. Marvin Stone

Biosystems and Agricultural Engineering
Oklahoma State University

Von Neuman Architecture

- Control unit
 - Fetches instruction from memory using address
 - Uses instruction to trigger a sequence of operations based on logic in the instruction ROM
 - Fetches data from an places data into memory based on addresses information in the instruction

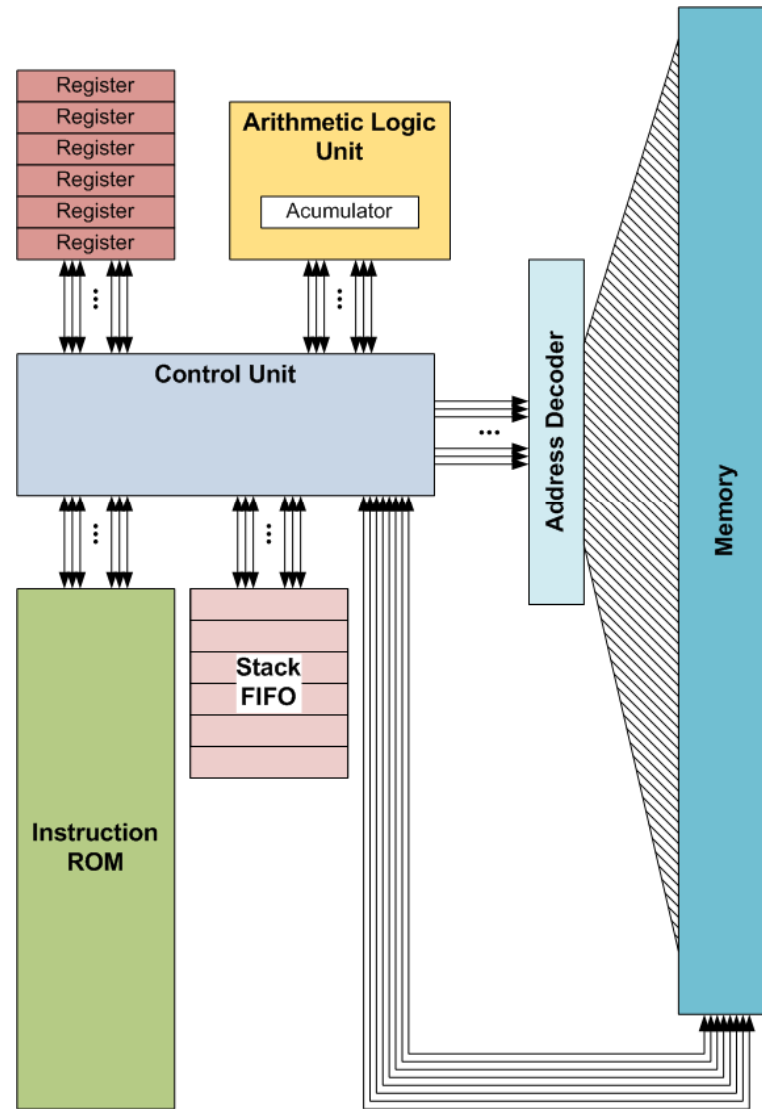

Harvard Architecture

- Like the Von Neuman architecture, but uses Data memory for data and instruction memory for instructions (code)

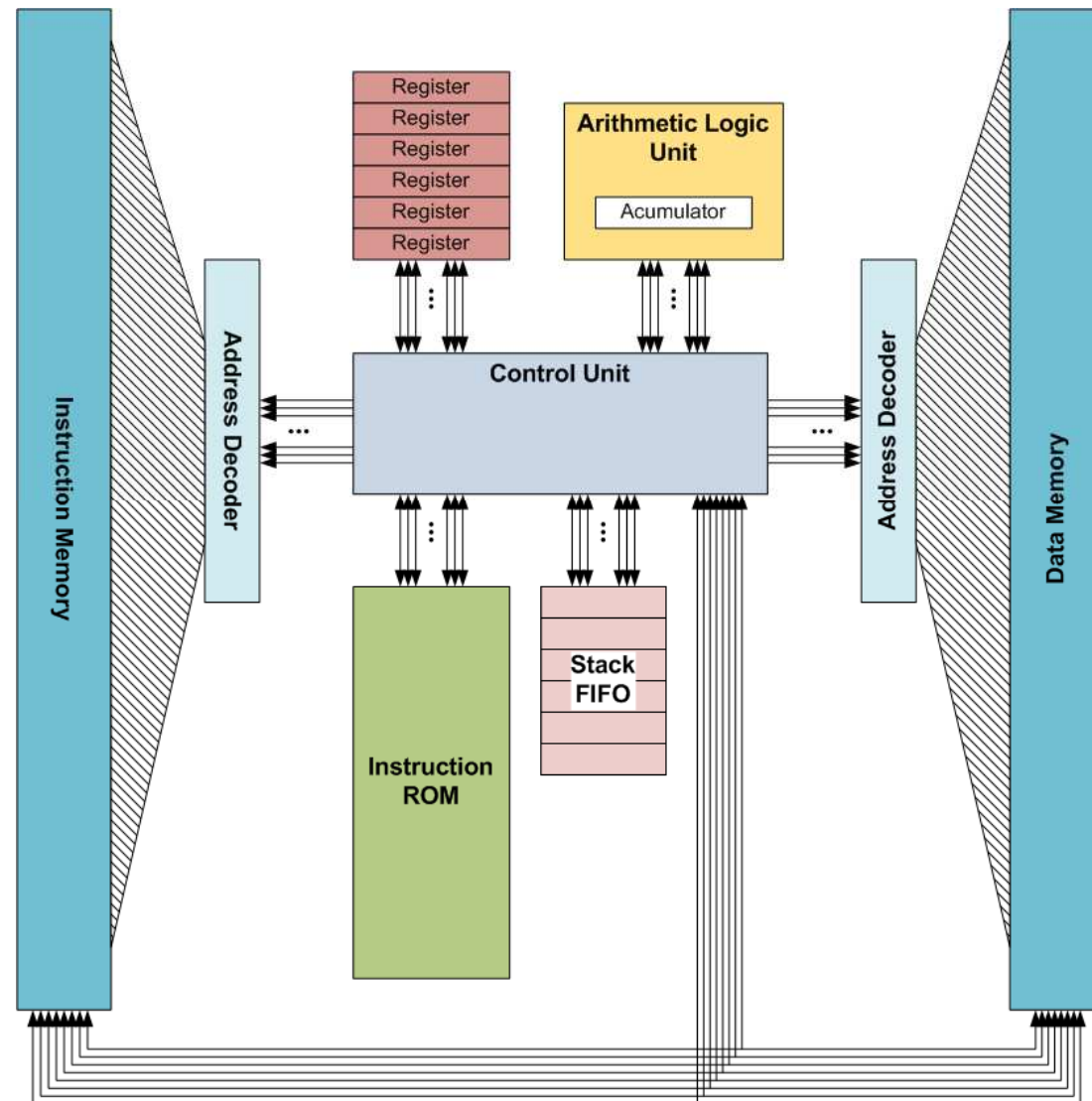

Address and Memory Pair

- Each memory location has a unique address and the memory is normally structured in an ordered list
- The Addresses are Pointers to memory when the pointed to object is the size of the memory width
- Objects in memory may be larger than memory width and each object may have a pointer

Address 0
Address 1
Address 2
Address 3
Address 4
Address 5
Address 6
Address 7

⋮

Address n-7
Address n-6
Address n-5
Address n-4
Address n-3
Address n-2
Address n-1
Address n

Memory 0
Memory 1
Memory 2
Memory 3
Memory 4
Memory 5
Memory 6
Memory 7

⋮

Memory n-7
Memory n-6
Memory n-5
Memory n-4
Memory n-3
Memory n-2
Memory n-1
Memory n

Pointers and Objects in memory

- Objects may be any size, made up a basic data type or types
- Pointers are an ordered list and incrementing a pointer results in a pointer to the next object

